

ST90CP10 ST90CB10 ST90WH10

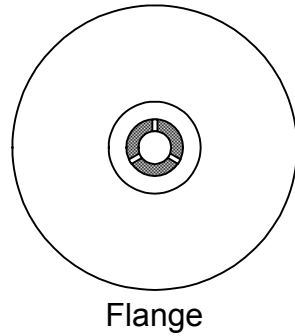

Flange

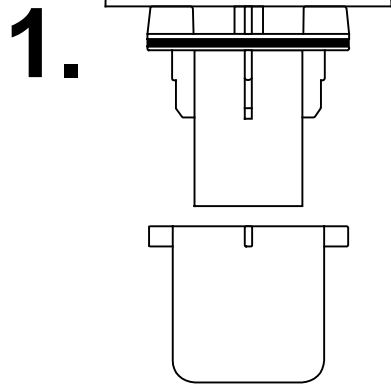

The Trap provides a flow rate of 26 litres per minute when tested in accordance with EN274-2:2002. The flow rate can be seriously impaired if an adequate fall is not maintained throughout the length of the waste pipe.

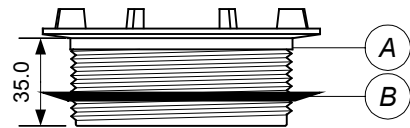

Install Trap into shower tray by assembling parts A, B, C, D & E as illustrated.

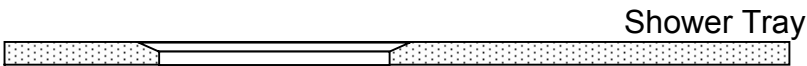

Shower Tray

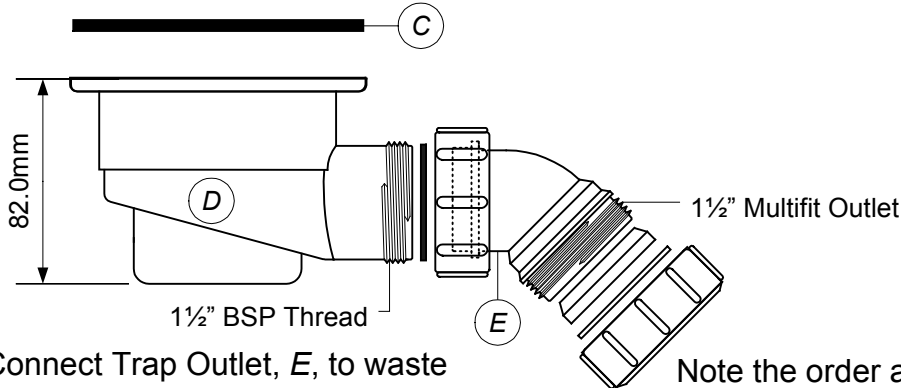

Connect Trap Outlet, E, to waste pipe, ensuring that the pipe is adequately supported. Test the installation.

Note the order and position of the Sealing Washers. Failure to do so can result in water leakage.

2.

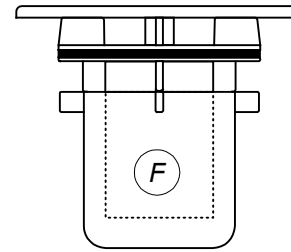

Insert Cup, F, and Flange Assembly ensuring that it is pushed down fully.

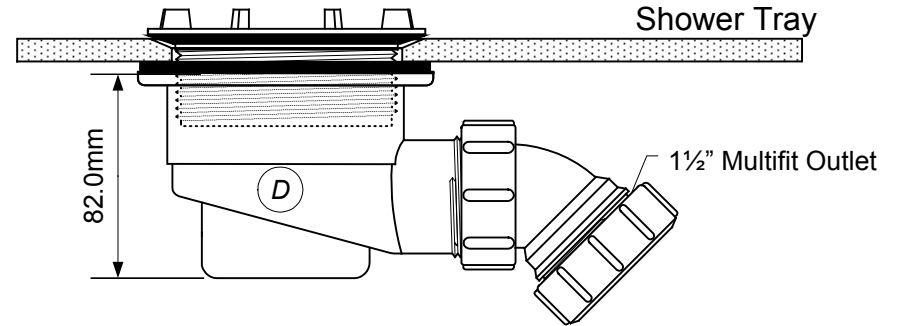

Shower Tray

3. Completed Assembly

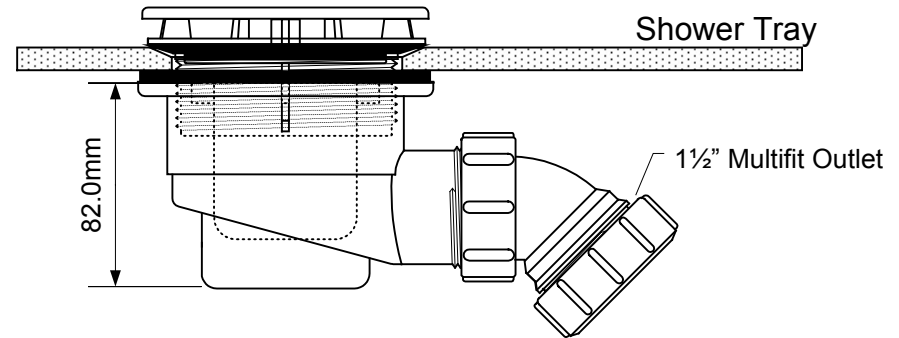

Shower Tray

After Care:

Regular maintenance is essential to retain a high performance flow rate. Remove the Flange Assembly and Cup, F, and thoroughly clean all the parts. Flush through the Trap Body with clean water and carefully replace the parts.