

Installation Instructions For:
ST90CP10-HP
ST90CB10-HP
ST90WH10-HP

90mm x 50mm WATER SEAL HIGH PERFORMANCE SHOWER TRAP

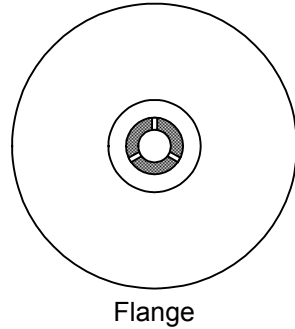

1.



The Trap provides a flow rate of 50 litres per minute when tested in accordance with EN274-2:2002. The flow rate can be seriously impaired if an adequate fall is not maintained throughout the length of the waste pipe.

In order to maintain a high performance flow rate, two sealing washers are supplied. If the thickness of the waste outlet hole, 'X' measures over 6mm, the thinner washer, C¹, should be used. If less than 6mm, use the thicker washer, C².

Install Trap into shower tray by assembling parts A, B, C, D & E as illustrated.

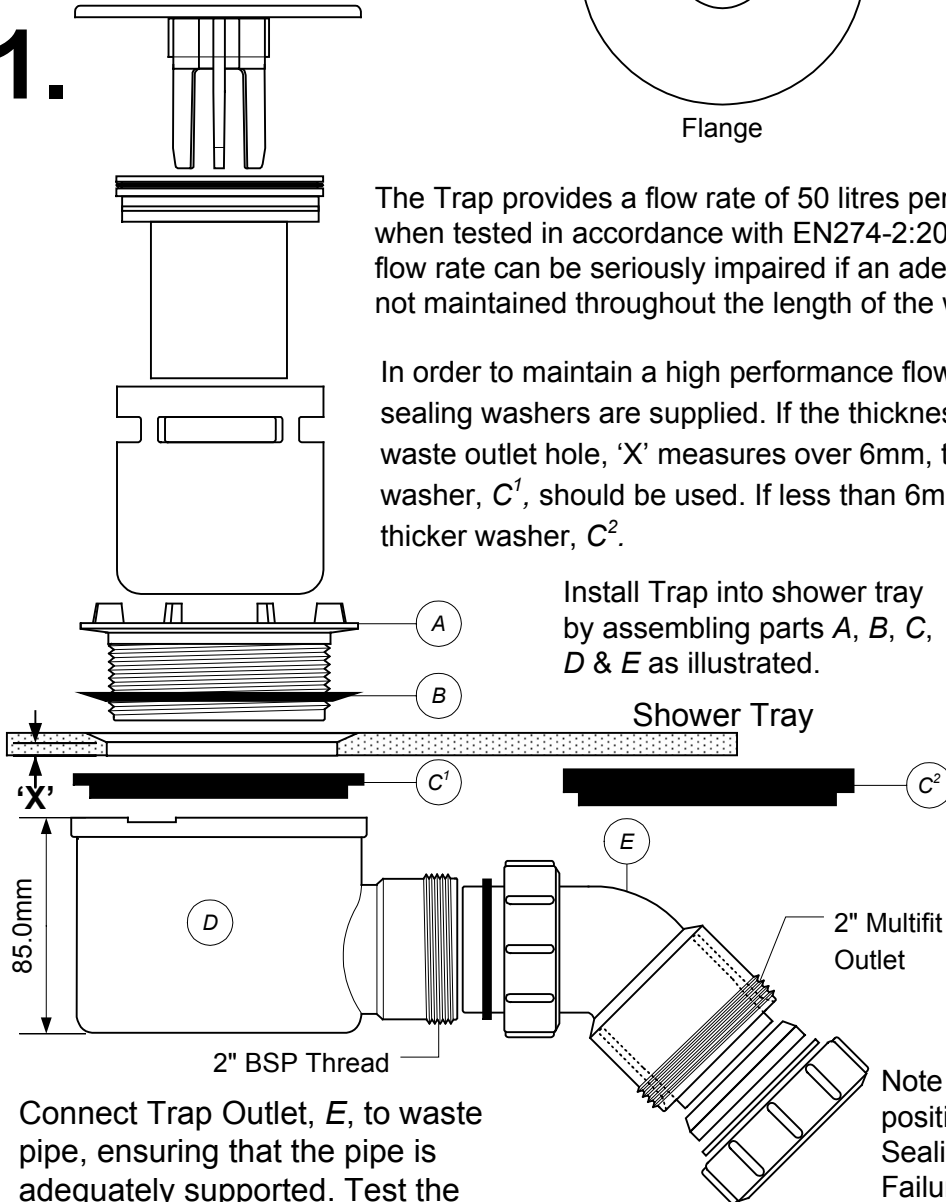

Connect Trap Outlet, E, to waste pipe, ensuring that the pipe is adequately supported. Test the installation.

Note the order and position of the Sealing Washers. Failure to do so can result in water leakage.

2.

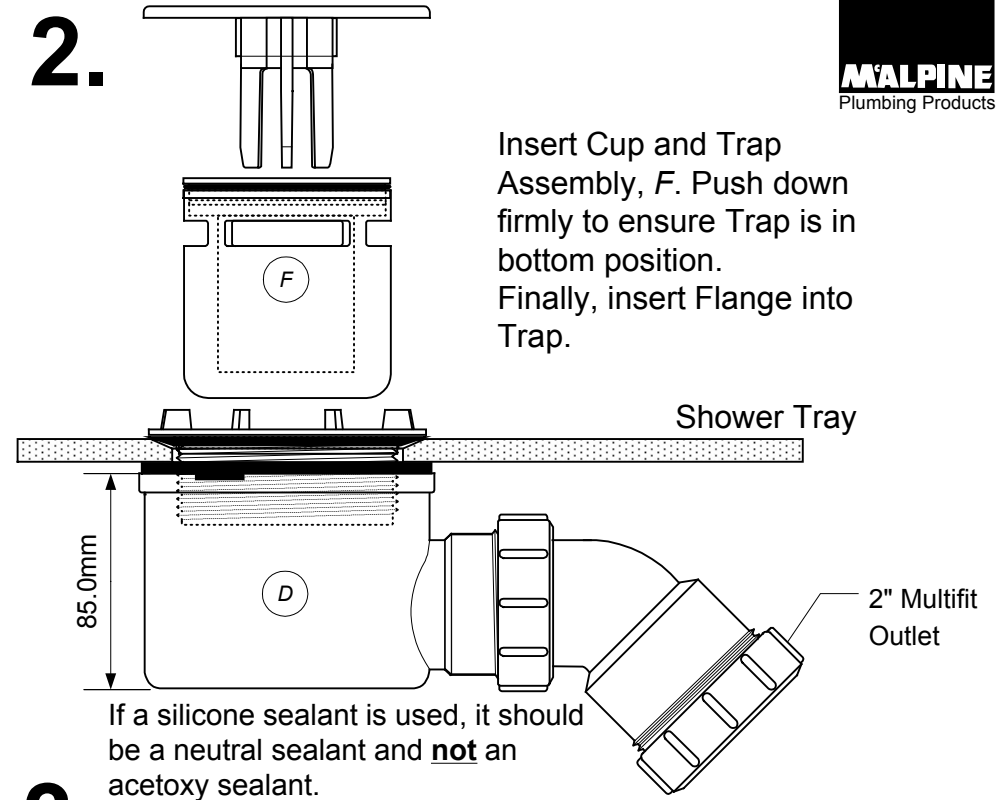

Insert Cup and Trap Assembly, F. Push down firmly to ensure Trap is in bottom position. Finally, insert Flange into Trap.

If a silicone sealant is used, it should be a neutral sealant and **not** an acetoxy sealant.

3. COMPLETED ASSEMBLY

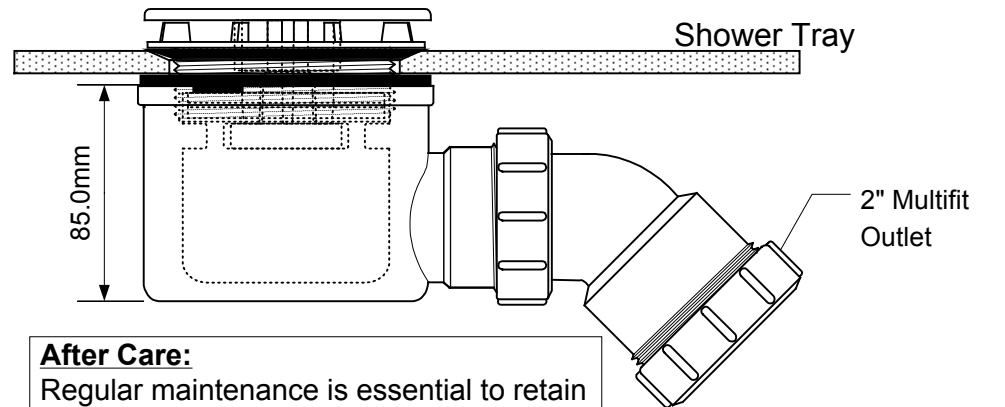

After Care:

Regular maintenance is essential to retain a high performance flow rate. Remove the Flange and Trap Assembly, F, and thoroughly clean all the parts. Flush through the Trap Body with clean water and carefully replace the parts.