

85mm x 50mm WATER SEAL SHOWER TRAP

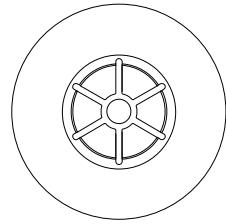

STW6-95
STW8-95
STW8B-95



GRID & FLANGE

The Trap provides a flow rate of 20 litres per minute when tested in accordance with EN274-2:2002. The flow rate can be seriously impaired if an adequate fall is not maintained throughout the length of the waste pipe.

Install Trap into shower tray by assembling parts A, C (*Ribbed side down*), D & E as illustrated. Flange A can be tightened using spanner supplied (H).

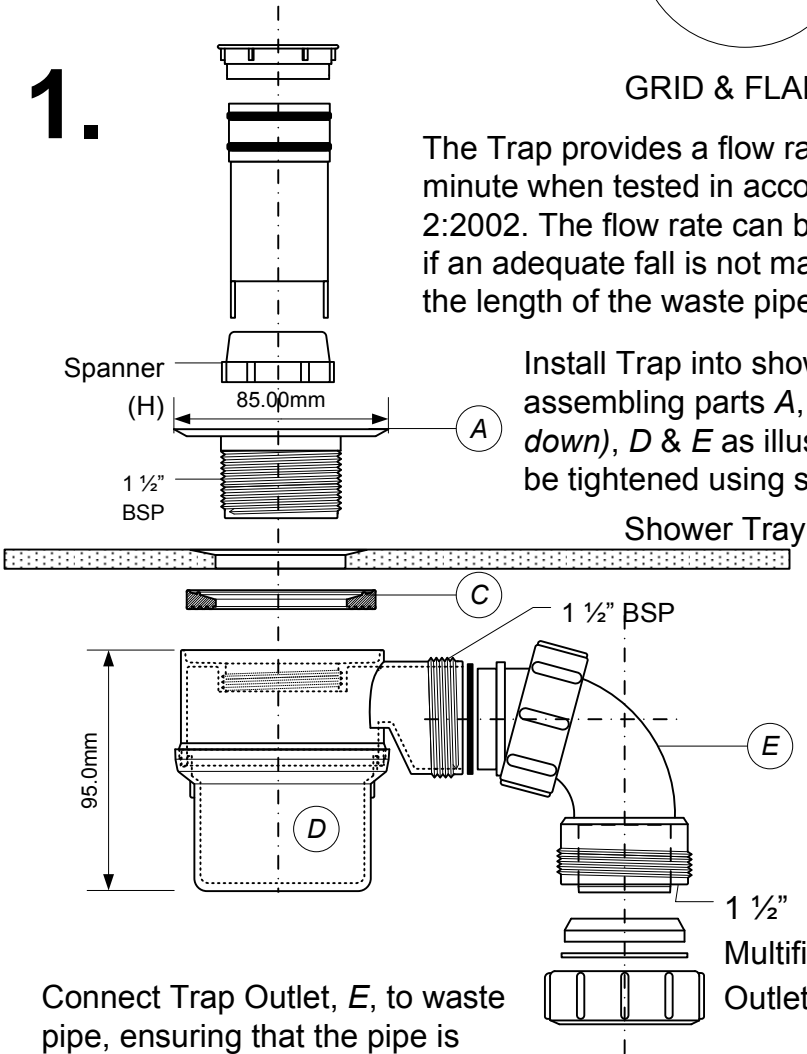

Connect Trap Outlet, E, to waste pipe, ensuring that the pipe is adequately supported. Test the installation.

DO NOT OVERTIGHTEN, HAND TIGHT + ¼ TURN IS SUFFICIENT

2.

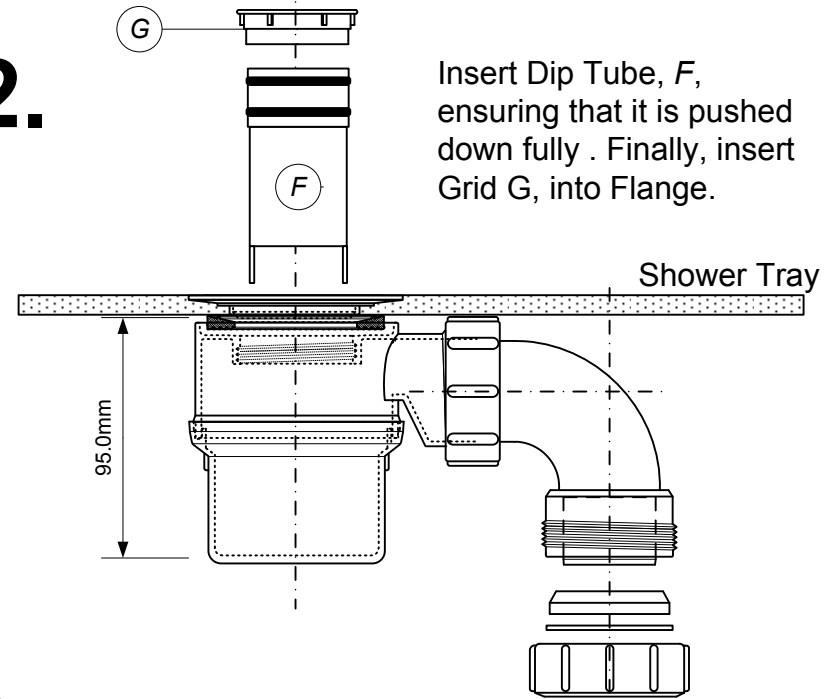

Insert Dip Tube, F, ensuring that it is pushed down fully. Finally, insert Grid G, into Flange.

3. Completed Assembly

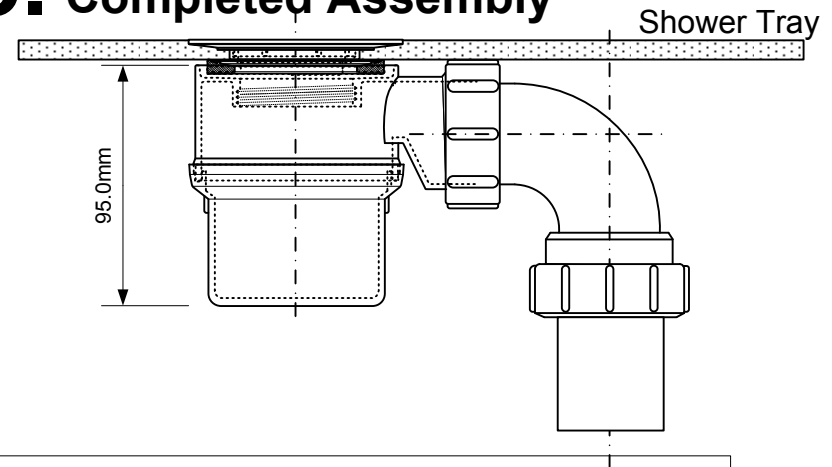

After Care:

Regular maintenance is essential to retain a high performance flow rate. Remove the Grid, G, and Dip Tube, F, and thoroughly clean all the parts. Flush through the Trap Body with clean water and carefully replace the parts.