

# INSTALLATION INSTRUCTIONS

## FOR THE GLIDE SINGLE SLIDER ROUND ENCLOSURE

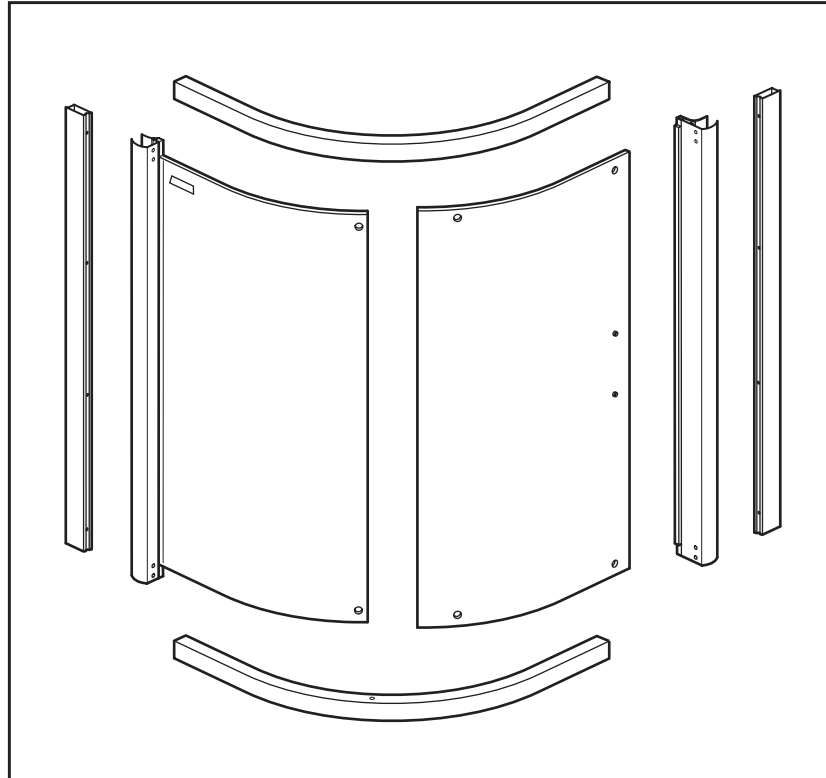

### **IMPORTANT - PLEASE READ**

- Please read these instructions carefully before assembly and installation.
- Please inspect immediately upon receipt for damage that may have been caused in transit.
- Damage reported later cannot be accepted.
- We recommend that two people handle the assembly of this enclosure.
- Before installation, you must ensure that the shower tray is level in all directions and completely sealed to the tiles.
- This product must only be fitted onto tiled or waterproof surfaces.
- The wall plugs and screws supplied are for use on solid walls and floors only. Any other surface will require alternative fixings.
- The enclosure when fitted, must not overhang the front of the tray.
- Please leave this instruction leaflet with the customer.



## **HINTS & TIPS**







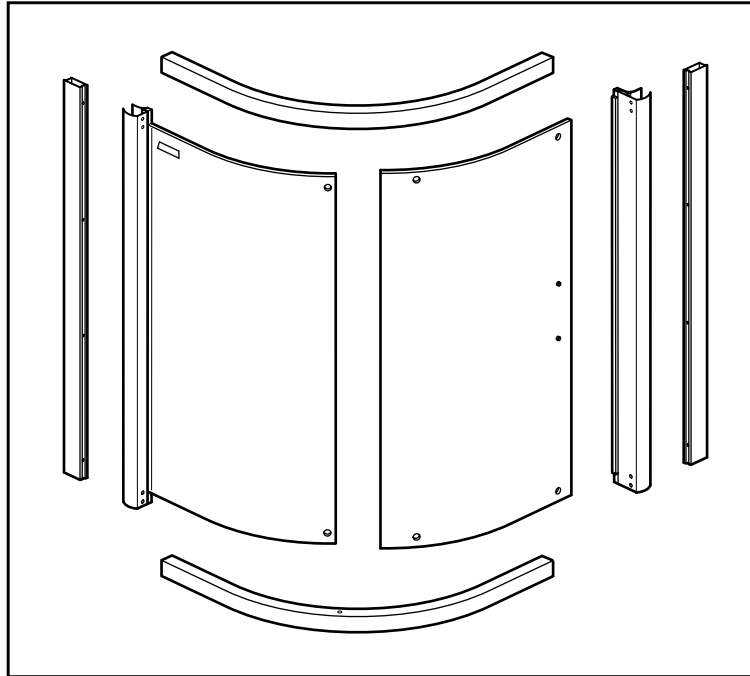



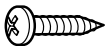
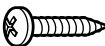



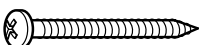

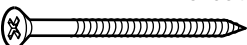



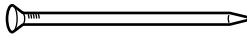
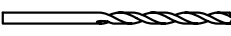

- Surfaces to be siliconed should be de-greased in accordance with silicone suppliers instructions, observing any safety instructions.
- Ensure there are no hidden pipes or cables in the wall before drilling.
- If using power tools (e.g. to drill holes) wear safety glasses and always disconnect tools from the power supply after use.
- If drilling holes in ceramic tiles use a piece of masking tape on the tile to stop the drill bit from slipping.
- DO NOT use your drill on hammer action when drilling holes in ceramic tiles.
- Use the opened out enclosure packaging to protect your floor and wall while assembling.

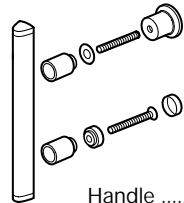
## **CARE & MAINTENANCE**

- To prevent the formation of water spots on the glass, use the squeegee supplied in the installation fixing pack to wipe down the glass after every shower.
- Always use plenty of water and a soft cloth or sponge to wipe down all aluminium sections and plastic parts.
- Do not use any solvent or abrasive chemicals to clean this product.
- We recommend that this product is cleaned with Showerlux 'Showerclean' once a week. This will help to reduce the build up of lime scale.
- Showerlux enclosures and screens are generally maintenance free. However, it may be necessary to lubricate roller assemblies or other moving hinge parts occasionally. Use a high quality silicone spray on the moving parts as required.

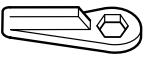

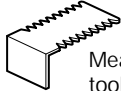
## SINGLE SLIDER ROUND CONTENTS

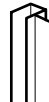
BAG 1		BAG 2		
 60008 <b>A</b> 13mm Screw ..... x 4	 4189514320 <b>B</b> 14mm Screw ..... x 4	 60140 <b>L</b> 9.5mm Screw ..... x 8	 60005 <b>M</b> 13mm Screw ..... x 2	 GL00004 <b>X</b> Top roller assembly x 2
 60042 <b>C</b> 35mm Screw ..... x 8	 GL00006 <b>D</b> Fixed panel bracket .... x 2	 62064 <b>N</b> 65mm Screw ..... x 8	 25006 <b>O</b> Wall plug ..... x 8	 GL00005 <b>Y</b> Bottom roller assembly x 2
 201746 <b>E</b> Bracket cover ..... x 2	 240240 <b>F</b> Hexagonal cam ..... x 4	 62092 <b>P</b> Centre punch ..... x 1	 62072 <b>Q</b> 2.8mm Drill bit ..... x 1	
 22722 <b>G</b> Cam cover cap ..... x 6	 201761 (22729) <b>H</b> Buffer ..... x 2	 20795 <b>R</b> Screw cover ..... x 8	 2210 <b>S</b> Wall channel cap .... x 2	<b>SEALS</b>
 GL00009 <b>I</b> Handle ..... x 1	 2214 (L) 2215 (R) <b>J</b> Mag. frame cap .. x 1/1	 2211 (L) 2212 (R) <b>T</b> Frame cap ..... x 1/1	 62428 <b>U</b> 3mm Allen key ..... x 1	 2273 <b>Z1</b> Magnetic door seal .. x 1
	 22728 <b>K</b> Spanner ..... x 1	 62158 <b>V</b> Glass squeegee ..... x 1	 24828 <b>W</b> Measuring tool ..... x 1	 2195 <b>Z2</b> Horizontal seal ..... x 2
				 2271 <b>Z3</b> Vertical 11.5mm flap seal .... x 1

## EQUIPMENT NEEDED

- Crosshead screwdriver ● Drill ● 8mm Masonry bit ● Hammer ● Rubber mallet ● Tape measure ● Pencil
- Fine tooth saw ● Spirit level ● Masking tape ● Silicone sealant / Applicator ● De-greaser e.g. White spirit

Before assembly choose which side you want to open the door from. The current illustrations show the door closed on the right hand side and opening to the left. Should you require the opposite, assemble the fixed panel to the opposite configuration to that shown.

**STEP 1**

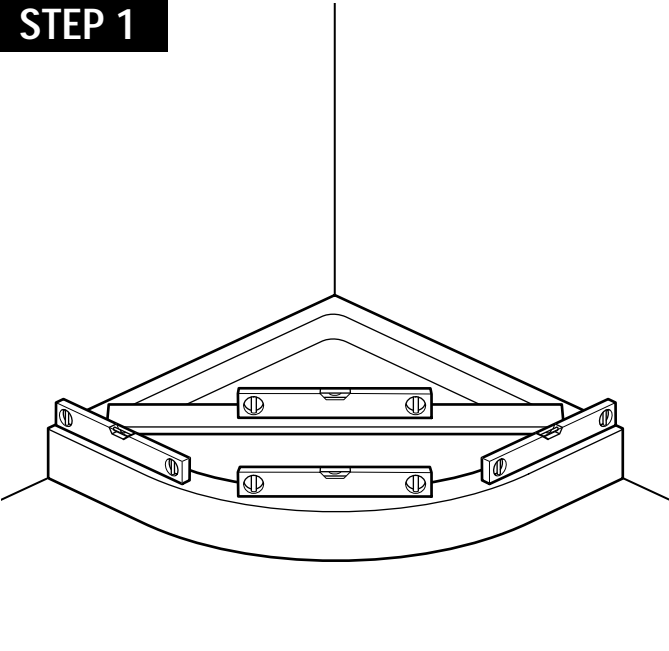

Check that the tray is level in all directions as shown above.

**STEP 2**

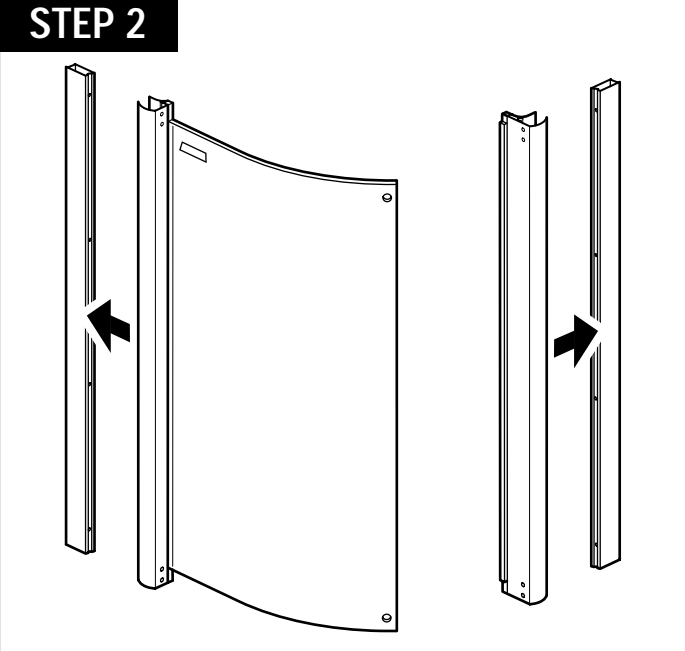

Remove the wall channels from the fixed panel and magnetic profile.

**STEP 3**

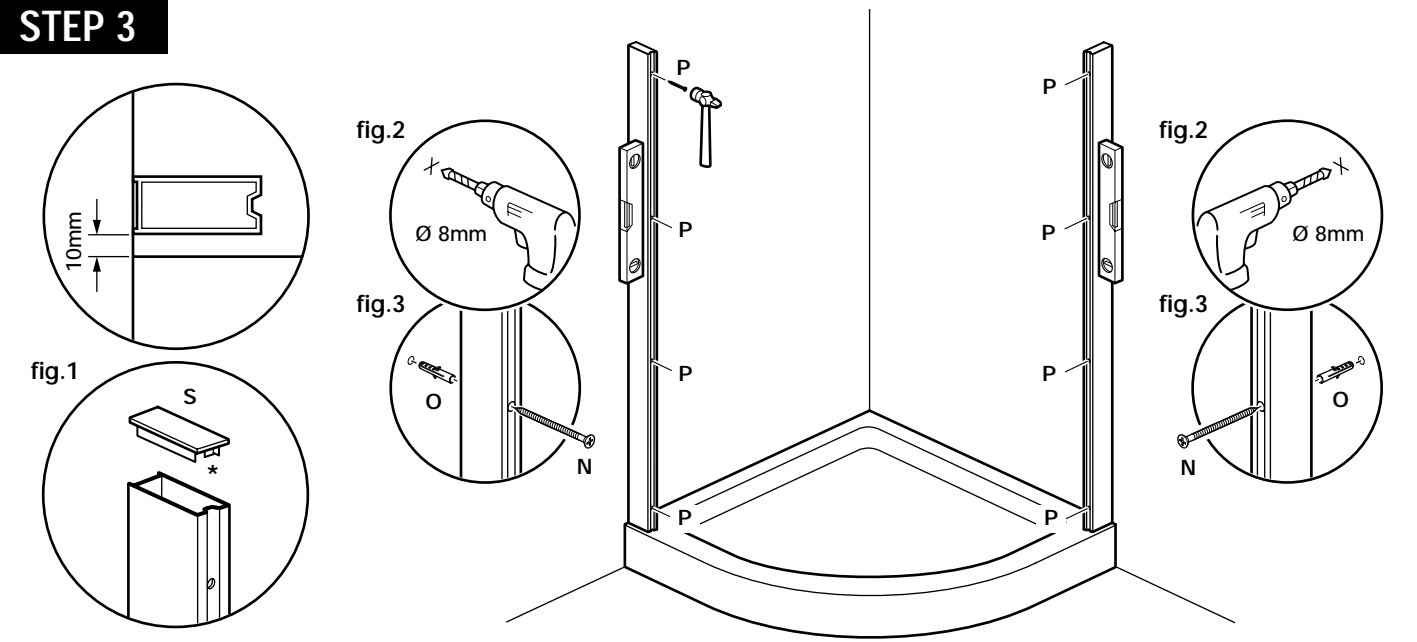

Position the wall channels onto the tray and against the wall, ensure the wall channels are perfectly vertical and 10mm from front edge of the tray using the measuring tool (W). Mark off drill hole positions onto the tiles using centre punch (P).

Fit the wall channel caps (S) to the top of the wall channels with the end tab (\*) in the position shown, tapping in place with a rubber mallet may help (fig.1).

Drill 8mm dia. holes to a depth of 50mm (fig.2).

Push-fit wall plugs (O) in beyond depth of tile. Fix the wall channels to the walls using the 65mm countersunk screws (N) (fig.3).

## STEP 4

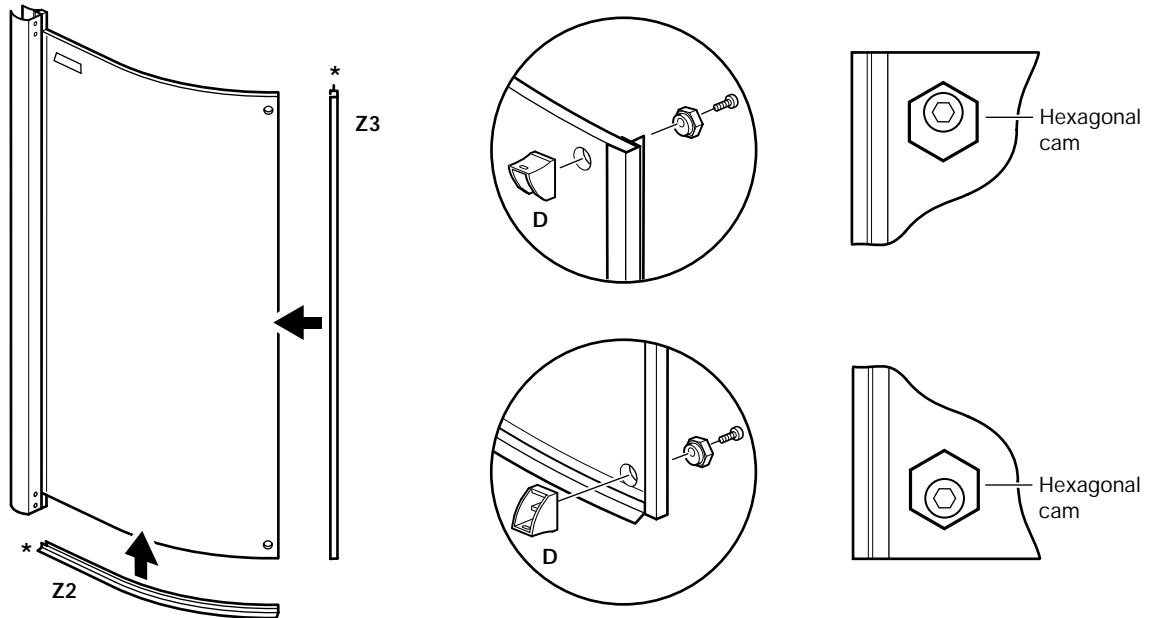

**NOTE:** Use the opened out enclosure packaging to protect your floor and wall while assembling.

Push-fit the vertical panel seal (**Z3**) onto the edge of the fixed panel (with flap on the inner face **\***). Cut to length and push-fit the horizontal seal (**Z2**) (with flap on the outer face **\***) onto the bottom edge of the fixed panel (logo badge at top).

Remove the screws and hexagonal cams from the fixed panel brackets (**D**) taking care not to lose the nuts. Attach the brackets to the top and bottom of the fixed panel (outside face) but do not fully tighten yet.

Set the hexagonal cams on the brackets to the positions shown above using spanner supplied (**K**).

## STEP 5

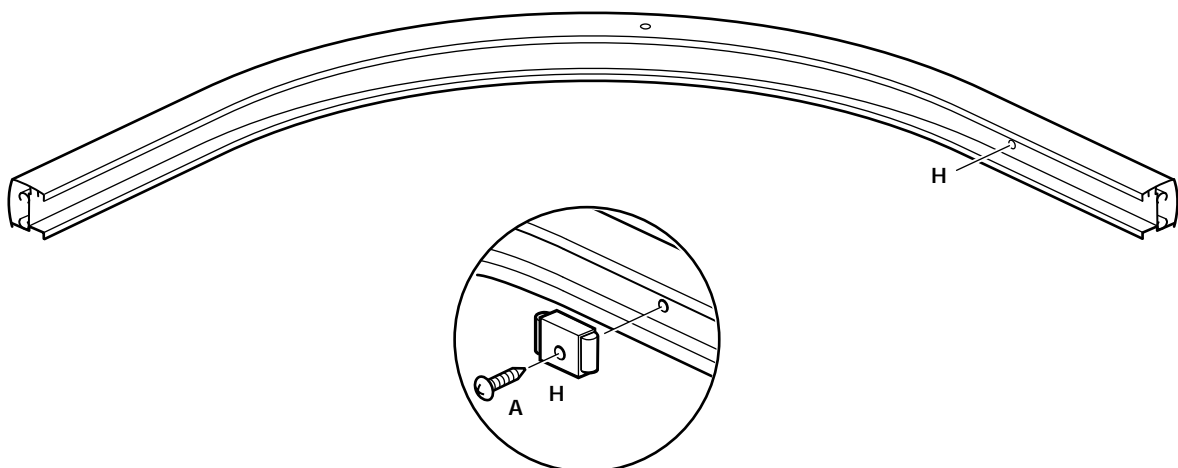

Select the top and bottom rails.

Fix buffers (**H**) to the pre-drilled hole on each rail using 13mm pan head screws (**A**).

## STEP 6

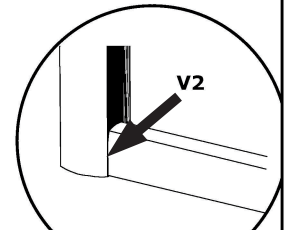
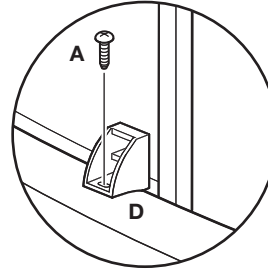
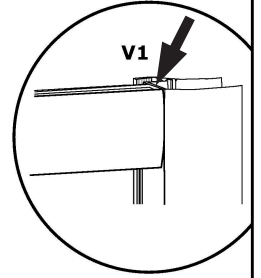
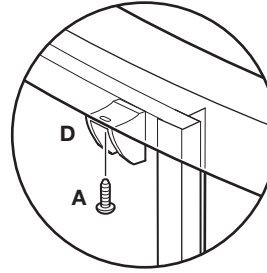
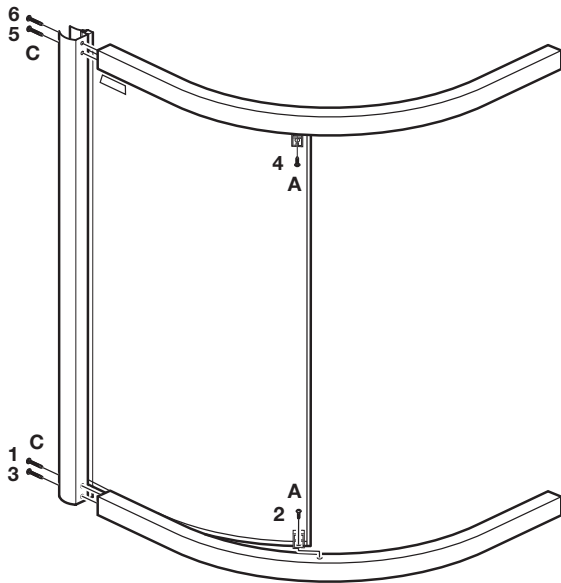

**NOTE:** Use the opened out enclosure packaging to protect your floor and wall while assembling.

With the fixed panel upright (logo badge in the position shown), attach the top and bottom rails using 35mm pan head screws (C) and 13mm pan head screws (A), fix in the order shown (1-2-3-4-5-6).

**Important:** Ensure the pre-drilled hole on the rails line up with the fixed panel brackets (D).

Ensure that when fixing the rails that the top and bottom rails are flush with the end of the profile (V1), also check that the rail is flush to the beginning of the vertical face see (V2). Do not fully tighten yet.

## STEP 7

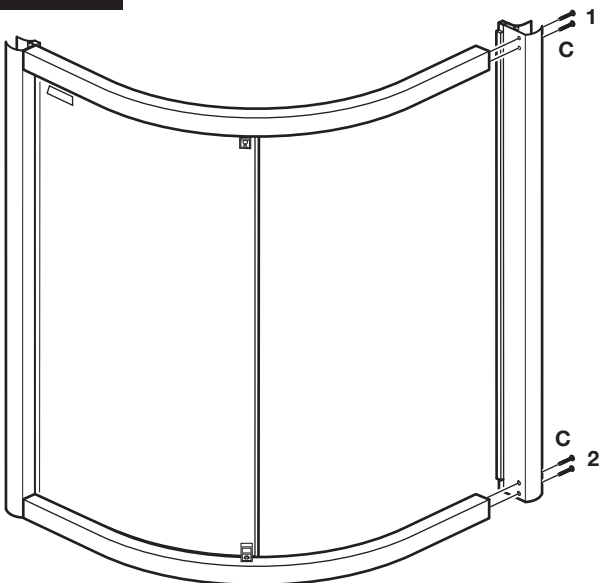

Attach the magnetic profile to the top and bottom rails using 35mm pan head screws (C), fix in the order shown (1-2).

Please check when fitting profile that the rails align as shown in step 6 illustrations V1 and V2.

Fully tighten all screws.

## STEP 8

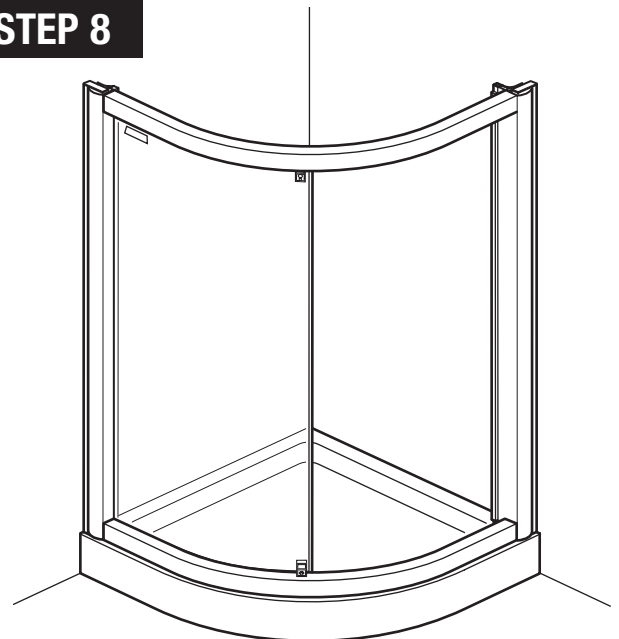

With help, lift and place the part assembled enclosure onto the tray.

Slide the first side onto a wall channel followed by the next (there is flexibility in the assembly to allow this).

The enclosure should sit with an even gap all around the tray with no part overhanging.

## STEP 9

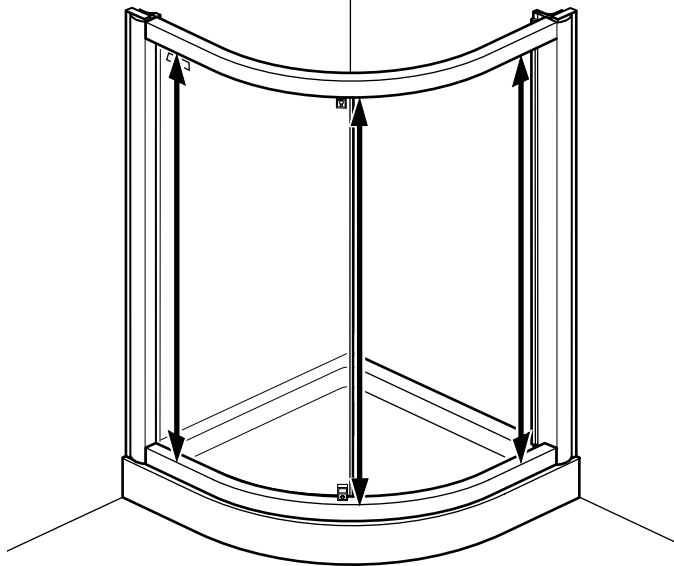

INSIDE ENCLOSURE

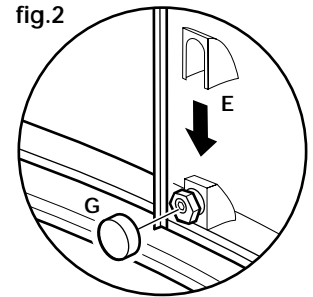
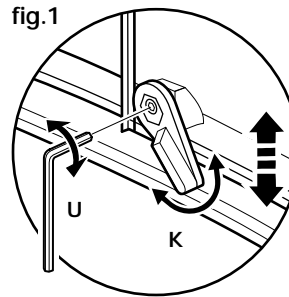

The distance between the top and bottom rails **MUST** be EQUAL at both ends and in the middle.

If adjustment is needed, from inside the enclosure loosen the bracket screw using the 3mm allen key (U) and adjust the cam on the bottom fixed panel bracket using the spanner supplied (K) (fig.1).

Once adjustment is complete, retighten the cam screw and push-fit cover caps (G) onto both brackets (top and bottom).

From outside the enclosure push-fit both bracket covers (E) onto the brackets (fig.2).

## STEP 10

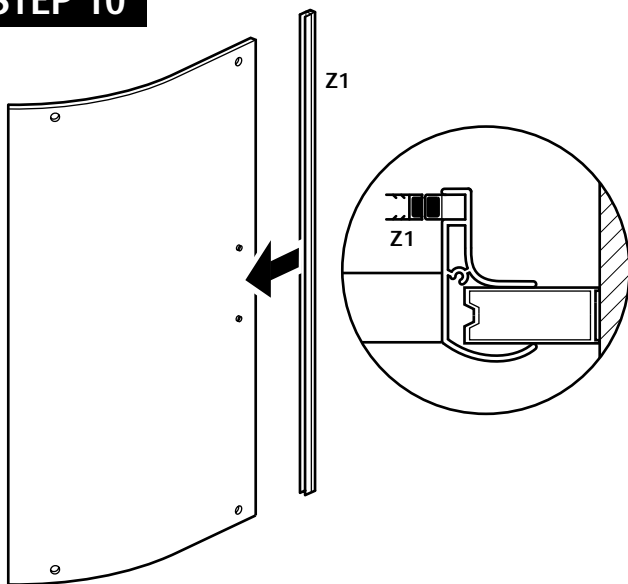

Push-fit the magnetic contact strip (Z1) onto the edge of the door (with door handle holes in the position shown).

**Important:** First check the magnetic contact strip (Z1) is the correct way around. Place the strip against the magnetic profile, when the correct way around the magnets will make even contact with each other as shown.

## STEP 11

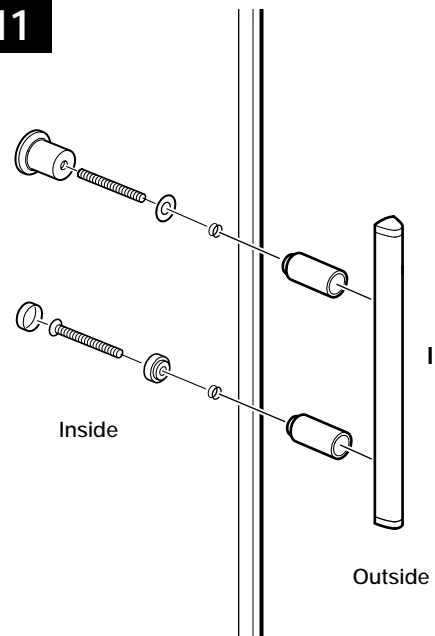

Attach the door handle (I) to the door as shown, ensure the doorknob on the inside is in the top position.

## STEP 12

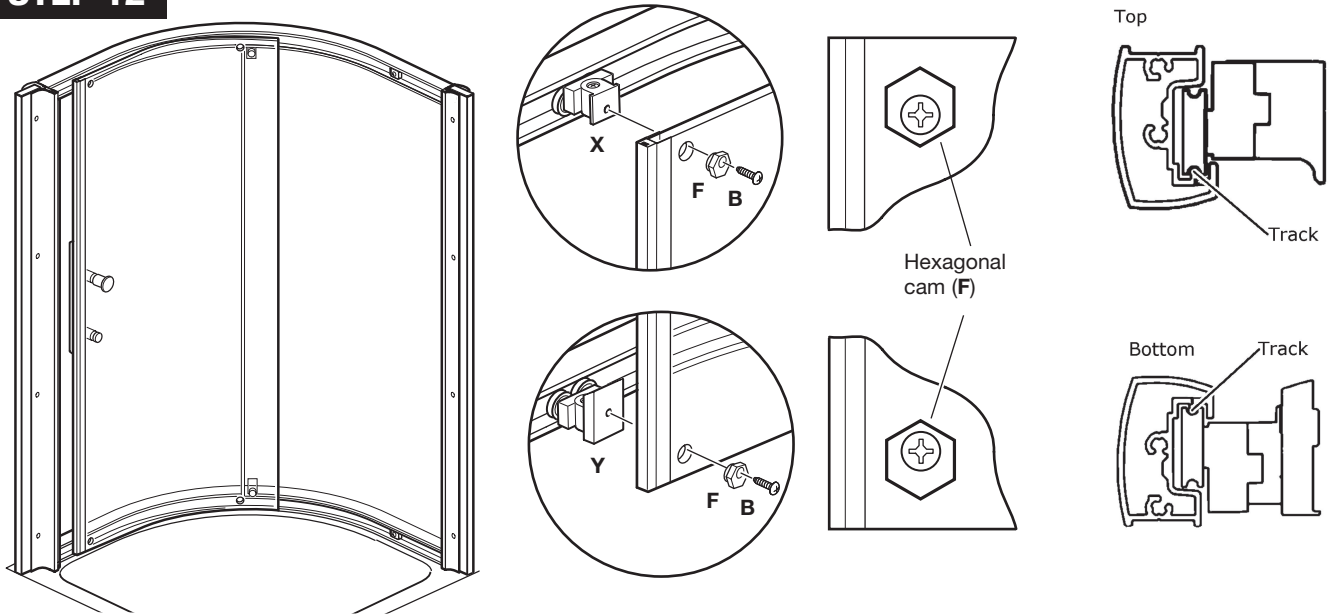

**NOTE:** Insert then remove the 14mm pan head screws (B) into the top and bottom roller assemblies (X & Y) before use to make them easier to assemble once inside the enclosure.

Carefully lift the door and carry into the enclosure (the correct way around).

Place the top rollers (X) into the top rail and attach to the top holes in the door using 14mm pan head screws (B) and hexagonal cams (F). Place the bottom rollers (Y) into the bottom rail and attach to the bottom holes in the door using 14mm pan head screws (B) and hexagonal cams (F). Use the spanner supplied (K) to set the cams in their highest positions as shown.

Ensure when fitting the top and bottom wheel assemblies that the wheels are positioned onto the track. Ensure that the assemblies are not positioned on the outer edge of the rails as this will damage your product and affect the performance.

## STEP 13

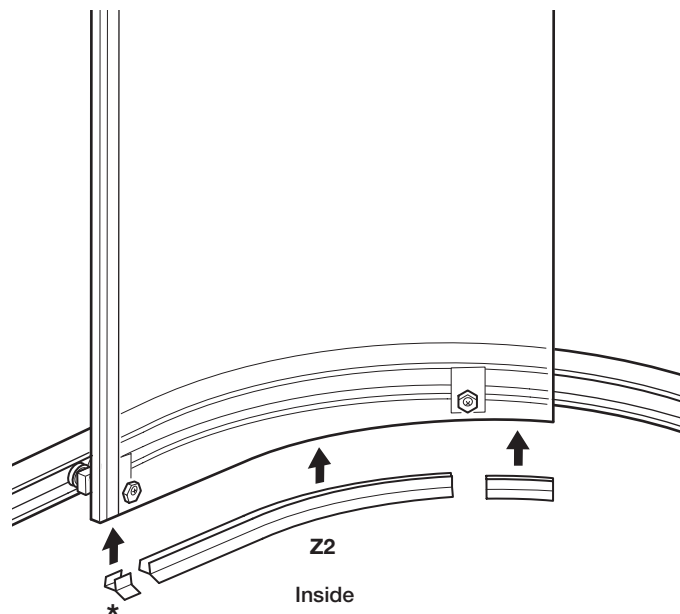

Cut to length and push-fit the horizontal seals (Z2) (with flaps on the inner face \*) onto the bottom edge of the door either side of the bottom rollers.

## STEP 14

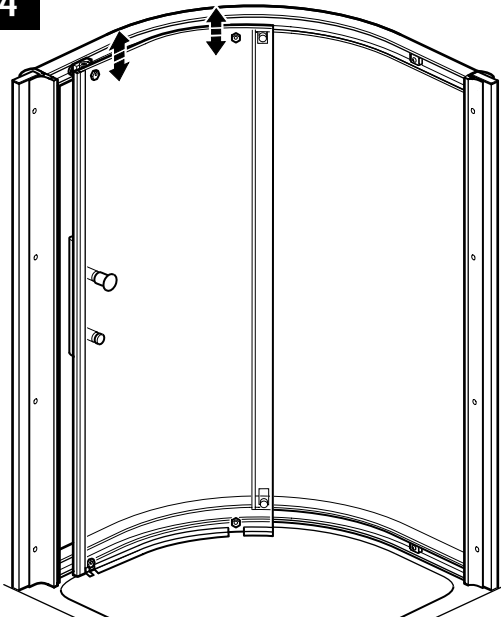

INSIDE ENCLOSURE

fig.1

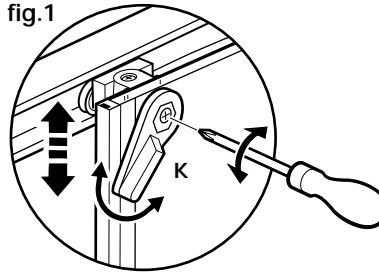

fig.2

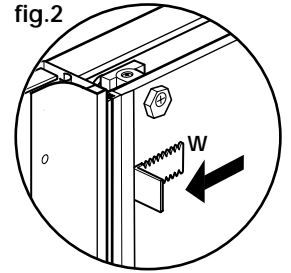
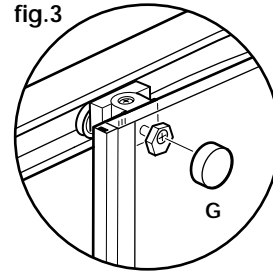

fig.3



To adjust the door to run smoothly, loosen the screws and adjust the cams on the rollers at the top of the door using spanner supplied (K) (fig.1).

Adjust the cams until you are happy with the opening and closing of the door and the magnetic contacts make full and even contact.

**NOTE:** To close any small gaps between the magnetic seals use the measuring tool (W) to push the seals closer together (fig.2). Once adjustment is complete retighten the screws and push-fit the cover caps (G) onto all four cams (fig.3).

## STEP 15

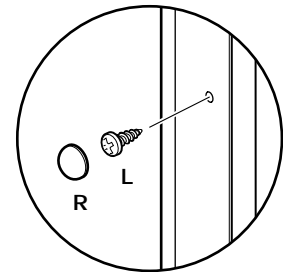
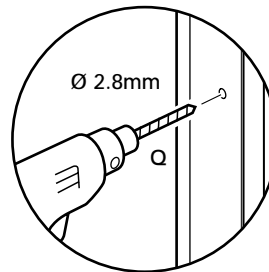
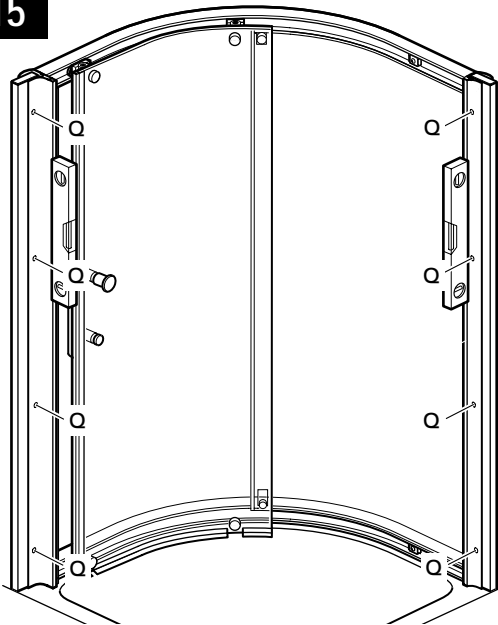

Centre the enclosure within the wall channels and ensure it is vertical.

From inside the enclosure, drill through the holes in the side profiles (as shown) into the wall channels using the 2.8mm drill bit supplied (Q).

Fix the sections together using eight 9.5mm pan head screws (L) and push-fit screw covers (R).

Make any adjustments to the door and fixed panel as required.

**STEP 16**

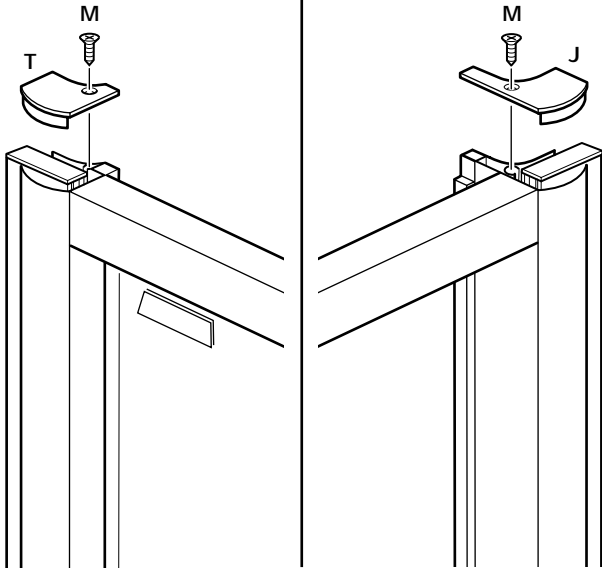

Place the correctly handed frame caps (**T & J**) as shown and fix using 13mm countersunk screws (**M**).

**STEP 17**

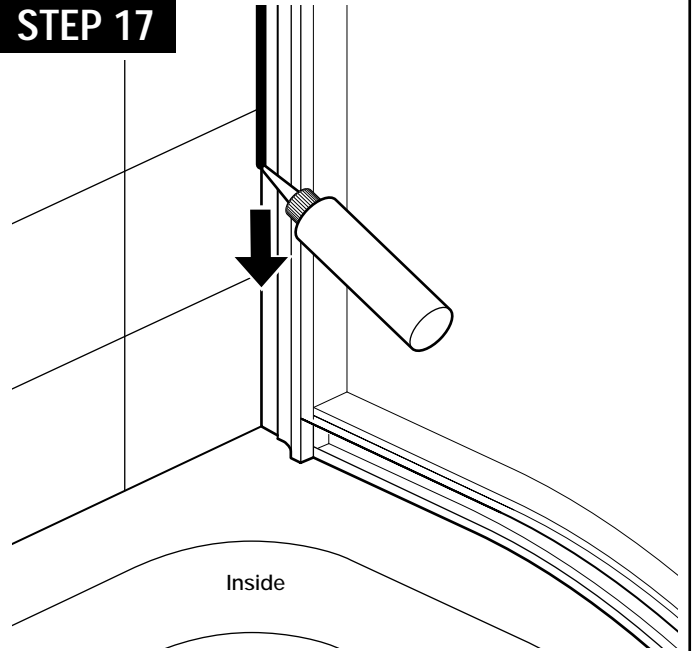

From the inside of the shower enclosure, silicone the entire vertical length of the wall channels up against the walls.

**Important:** Do not silicone the lower horizontal frame of the enclosure on the inside **or the ends of the vertical profiles of the frame.**

**STEP 18**

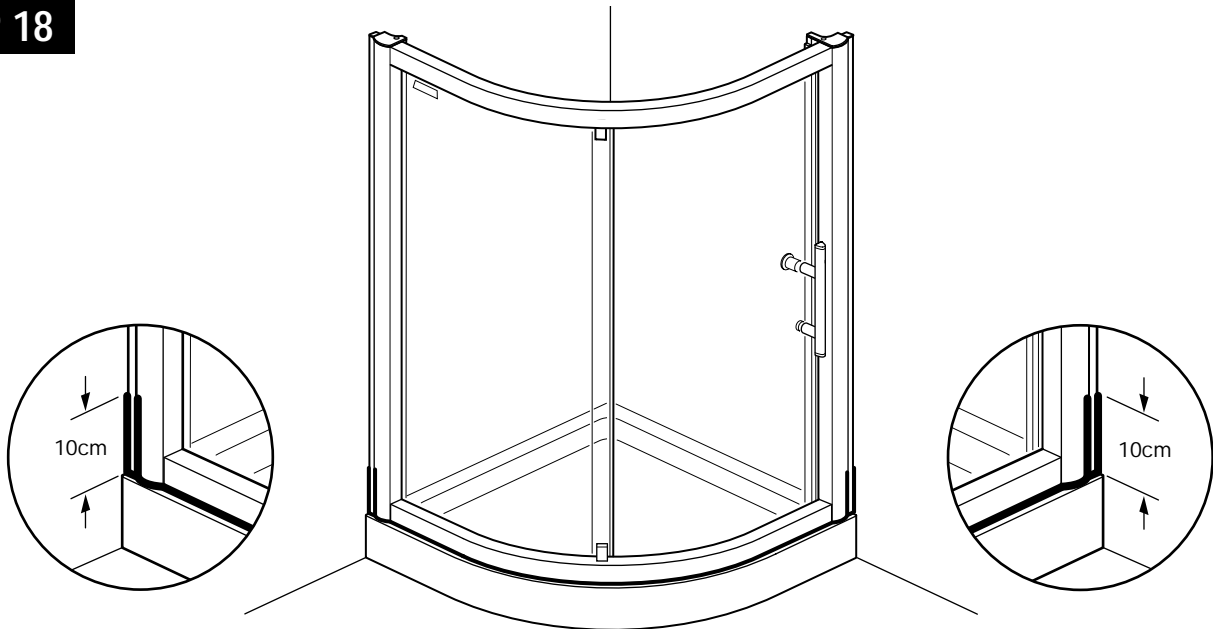

From outside the enclosure, silicone along the bottom of the enclosure on the shower tray all the way around and 10cm up each wall.

Also silicone 10cm up the joint between the wall channel and side profiles as shown.

# Single Slider Round Components

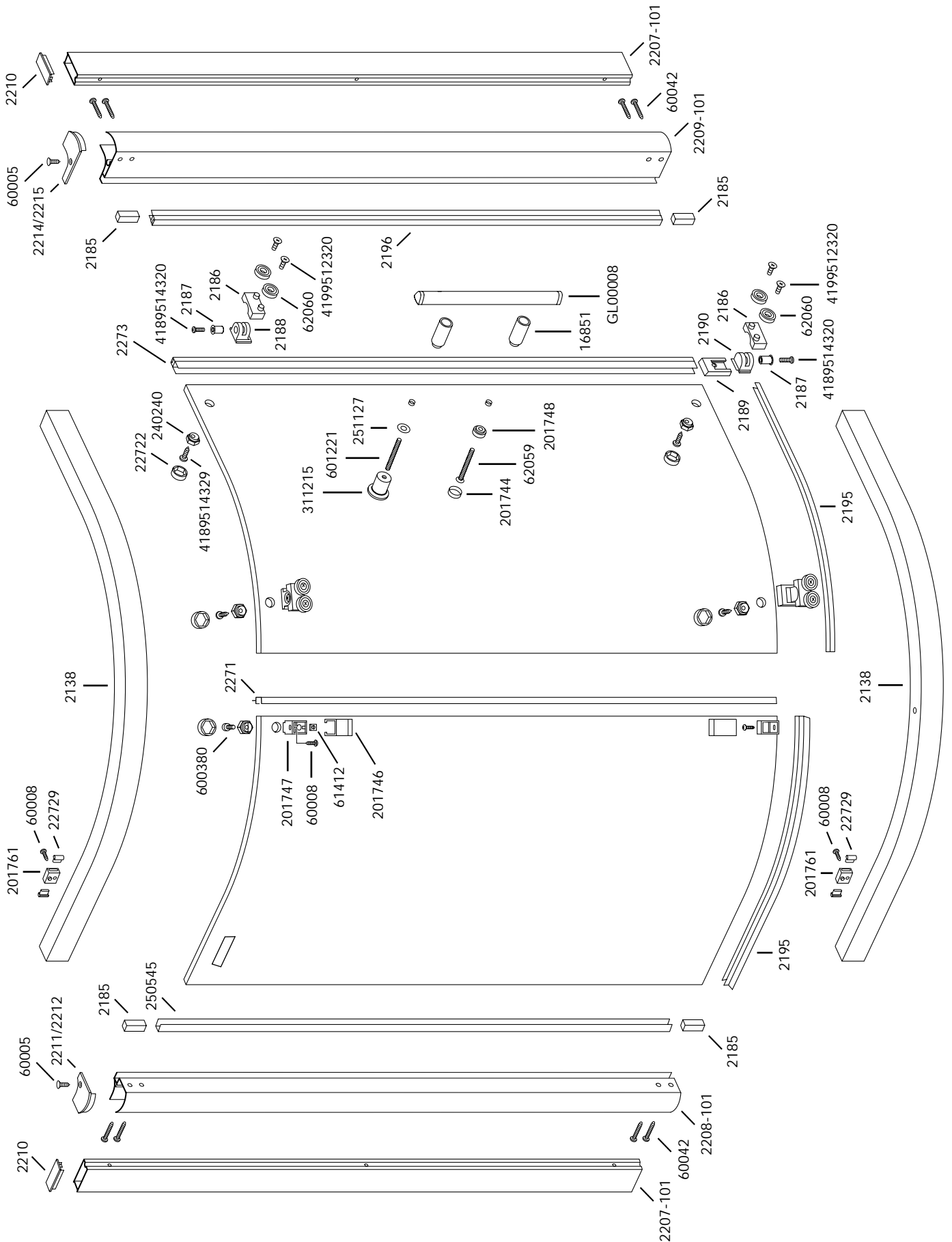



**SHOWERLUX HELPLINE: 02476 882518**

Fax: 02476 882539

Email: [technical@showerlux.co.uk](mailto:technical@showerlux.co.uk)

Email: [spares@showerlux.co.uk](mailto:spares@showerlux.co.uk)

**SHOWERLUX (UK) Ltd.**

Sibree Road, Coventry, West Midlands CV3 4FD

Tel: 02476 639400

Fax: 02476 305457